

Features:

- **Speziell entwickelt für beschaltungslosen Betrieb**
- **Niedrige Verluste, weiches Ausschalten**
- **Volle Sperrfähigkeit bei 140°C mit 50Hz**
- **Hohes di/dt und niedriger Wärmewiderstand durch NTV-Verbindung zwischen Silizium und Mo-Trägerscheibe**
- **Elektroaktive Passivierung durch a-C:H**
- **Specially designed for snubberless operation**
- **Low losses, soft recovery**
- **Full blocking capability at 140°C with 50Hz**
- **High di/dt and low thermal resistance by using low temperature-connection NTV between silicon wafer and molybdenum**
- **Electroactive passivation by a-C:H**

Elektrische Eigenschaften / Electrical properties

Höchstzulässige Werte / Maximum rated values

Periodische Spitzensperrspannung repetitive peak reverse voltage	$T_{vj} = 0^\circ\text{C} \dots T_{vj\text{max}}$ $f = 50\text{Hz}$	V_{RRM}	4500	V
Durchlaßstrom-Grenzeffektivwert RMS forward current	$T_C = 60^\circ\text{C}, f = 50\text{Hz}$	I_{FRMSM}	2240	A
Dauergrenzstrom mean forward current	$T_C = 85^\circ\text{C}, f = 50\text{Hz}$ $T_C = 60^\circ\text{C}, f = 50\text{Hz}$	I_{FAVM}	1140 1420	A A
Stoßstrom-Grenzwert surge forward current	$T_{vj} = T_{vj\text{max}}, T_P = 10\text{ms}$	I_{FSM}	26	kA
Grenzlastintegral I^2t -value	$T_{vj} = T_{vj\text{max}}, T_P = 10\text{ms}$	I^2t	$3,38 \cdot 10^6$	A^2s
Max. Ausschaltverluste max. turn-off losses	$I_{FM} = 2500\text{A}, V_{CL} = 2800\text{V}$, clamp circuit $L_C \leq 0,25 \mu\text{H}, R_{CL} = 68\Omega$ $C_{CL} = 3\mu\text{F}, D_{CL} = 34\text{DSH65}$ $T_{vj} = T_{vj\text{max}}$	W_{max}	4	MW

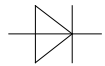

Elektrische Eigenschaften / Electrical properties

Charakteristische Werte / Characteristic values

Gleichsperrspannung continuous direct reverse voltage	failure rate $\lambda < 100$ estimate value	$V_{R(D)}$	typ. 2800	V
Durchlaßspannung forward voltage	$T_{vj} = T_{vjmax}, i_F = 2500A$	V_F	max 4,2	V
Schleusenspannung threshold voltage	$T_{vj} = T_{vjmax}$	$V_{(TO)}$	1,7	V
Ersatzwiderstand forward slope resistance	$T_{vj} = T_{vjmax}$	r_T	1,0	m Ω
Durchlaßrechenkennlinie On-state characteristics for calculation $V_F = A + B \cdot i_F + C \cdot \ln(i_F + 1) + D \cdot \sqrt{i_F}$ 250 A \leq $i_F \leq$ 3200 A	$T_{vj} = T_{vjmax}$	A B C D	max. 0,600 -0,0000339 -0,0750 0,0851	
Spitzenwert der Durchlaßverzögerungsspannung peak value of forward recovery voltage	$T_{vj} = T_{vjmax}, di_F/dt = 5000A/\mu s$ $I_{FM} = 4000A$	V_{FRM}	typ. 350	V
Sperrstrom reverse current	$T_{vj} = T_{vjmax}, V_R = V_{RRM}$	i_R	100	mA
Rückstromspitze peak reverse recovery current		I_{RM}	max 1500	A
Sperrverzögerungsladung recovered charge	$I_{FM} = 2500A, V_{CL} = 2800V,$ clamp circuit $L_{\sigma} \leq 0,25 \mu H, R_{CL} = 68\Omega$ $C_{CL} = 3\mu F, D_{CL} = 34DSH65$ $T_{vj} = T_{vjmax}$	Q_r	max 3500	μAs
Ausschaltverlust Energie turn-off energy		E_{off}	7,0	Ws
Abklingsantheit reverse recovery softness factor $F_{RRS} = \frac{(di_{rr}/dt)_{i=0}}{(di_{rf}/dt)_{max}}$	$I_{FM} = 2500A, V_R = 2800V$ $-di_{rr}/dt_{(i=0)} = 1000A/\mu s, dt = 200ns$ $T_{vj} = T_{vjmax}$	F_{RRS}	typ. 1,6	

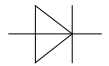

Thermische Eigenschaften / Thermal properties

Innerer Wärmewiderstand thermal resistance, junction to case	Kühlfläche / cooling surface beidseitig / two-sided, DC Anode / anode, DC Kathode / cathode, DC	R_{thJC}	max 0,0100 max 0,0178 max 0,0230	°C/W °C/W °C/W
Übergangs-Wärmewiderstand thermal resistance, case to heatsink	Kühlfläche / cooling surface beidseitig / two-sided einseitig / single sided	R_{thCK}	max 0,003 max 0,006	°C/W °C/W
Höchstzulässige Sperrschichttemperatur max. junction temperature		$T_{vj\ max}$	140	°C
Betriebstemperatur operating temperature		$T_{c\ op}$	0...+140	°C
Lagertemperatur storage temperature		T_{stg}	-40...+150	°C

Mechanische Eigenschaften / Mechanical properties

Gehäuse, siehe Anlage case, see appendix			Seite 3	
Si - Element mit Druckkontakt Si - pellet with pressure contact			65DSH45	
Anpreßkraft clampig force		F	27...45	kN
Gewicht weight		G	typ 850	g
Kriechstrecke creepage distance			30	mm
Luftstrecke air distance			17	mm
Feuchteklasse humidity classification	DIN 40040		C	
Schwingfestigkeit vibration resistance	f = 50Hz		50	m/s ²

Mit dieser technischen Information werden Halbleiterbauelemente spezifiziert, jedoch keine Eigenschaften zugesichert. Sie gilt in Verbindung mit den zugehörigen technischen Erläuterungen.
This technical information specifies semiconductor devices but promises no characteristics. It is valid in combination with the belonging technical notes

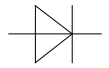

Maßbild / Outline drawing

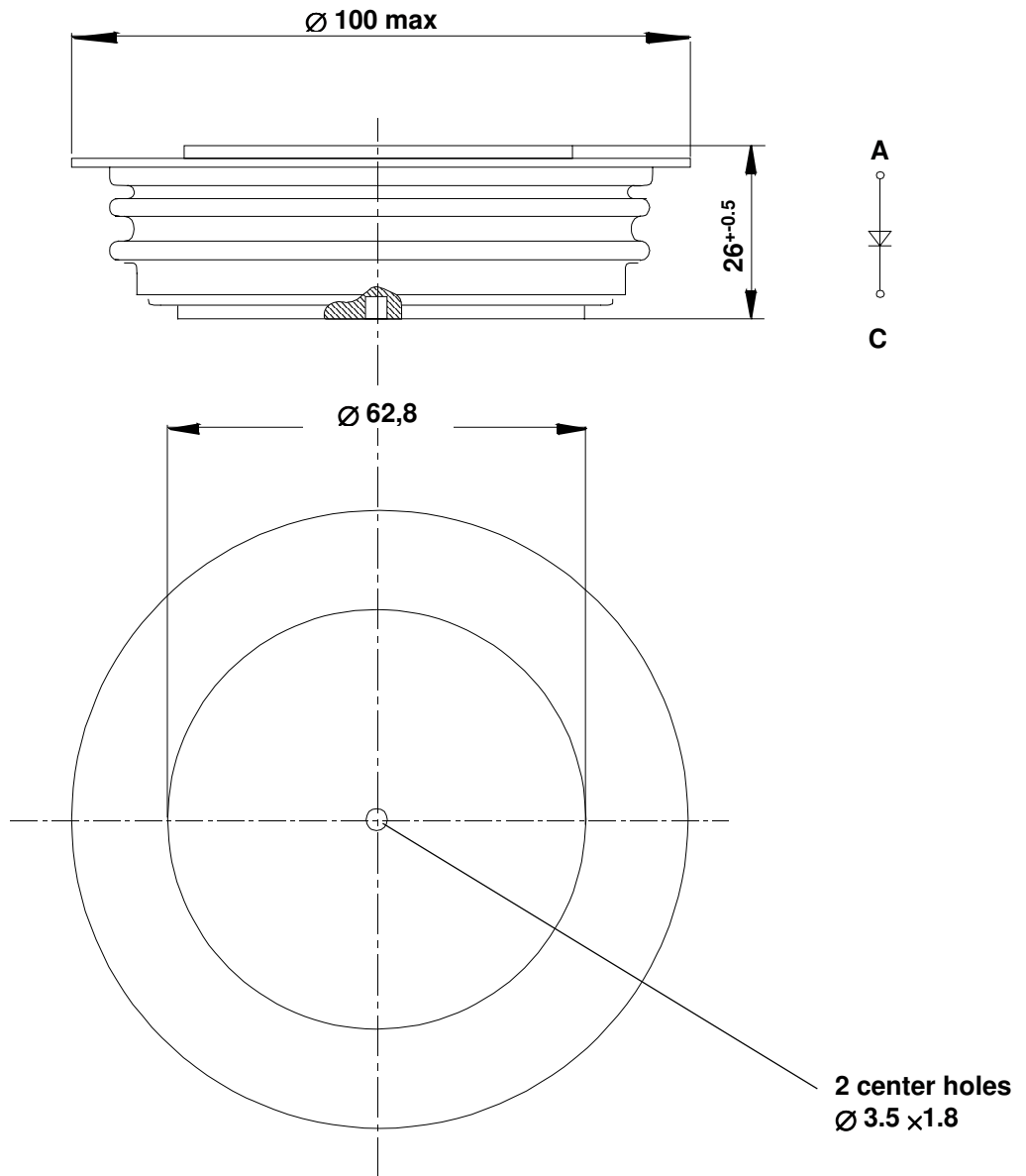

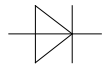

Durchlaßkennlinie / On-state characteristics $i_F = f(V_F)$
upper limit of scatter range

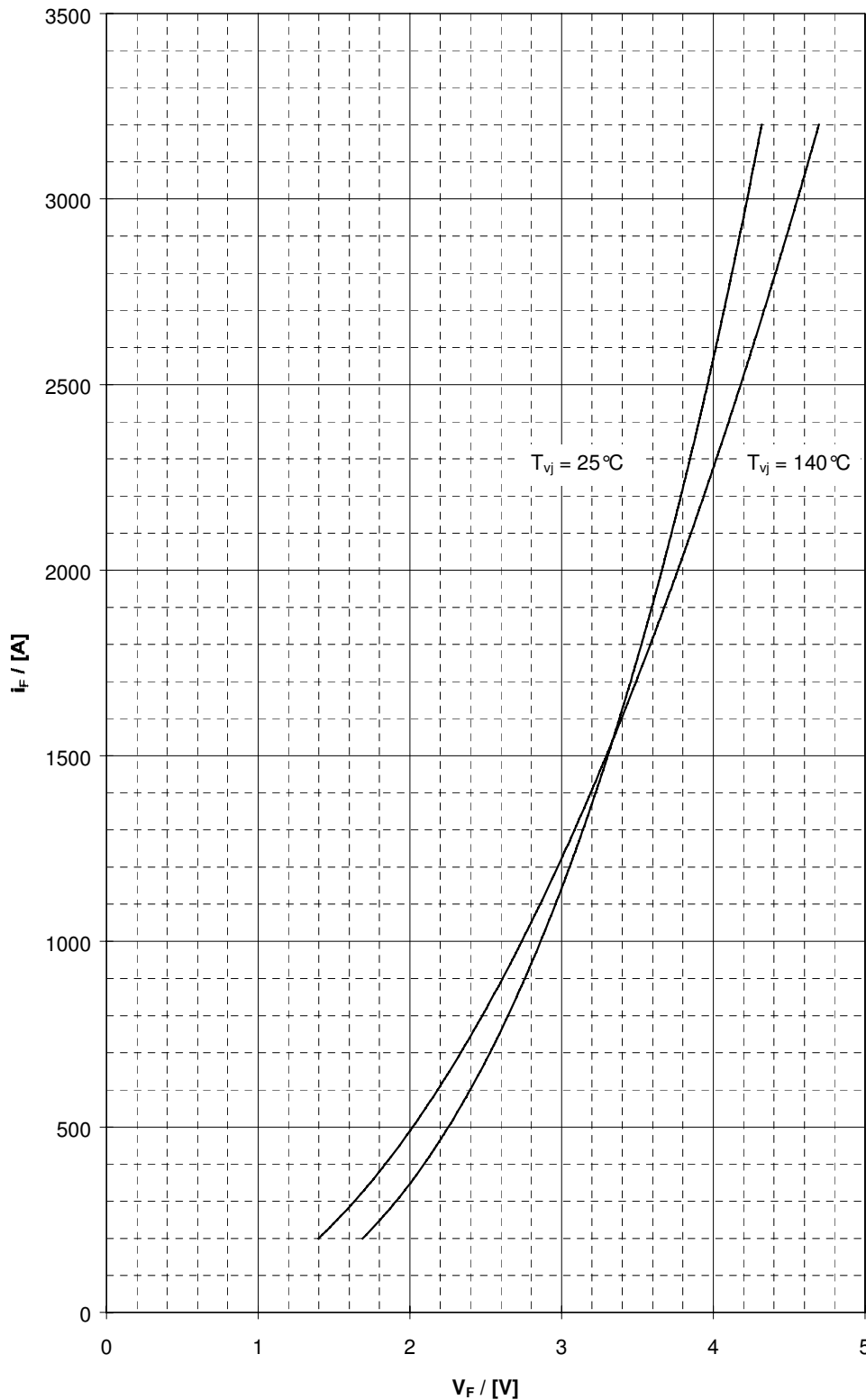



Transienter innerer Wärmewiderstand
Transient thermal Impedance $Z_{(th)JC} = f(t)$

$$Z_{th\,JC}(t) = \sum_n R_{th\,n} \cdot (1 - e^{-t/\tau_n})$$

	Double side cooled		Anode side cooled		Cathode side cooled	
	r [K/W]	[s]	r [K/W]	[s]	r [K/W]	[s]
1	0,0054	0,509	0,0106	3,78	0,01656	3,766
2	0,00261	0,0869	0,00307	0,284	0,00151	0,386
3	0,00122	0,0156	0,00251	0,066	0,00314	0,0844
4	0,00074	0,00302	0,0011	0,00957	0,00114	0,0122
5	0,00003	0,000819	0,00052	0,00221	0,00065	0,00265
Σ	0,01	-	0,0178	-	0,023	-

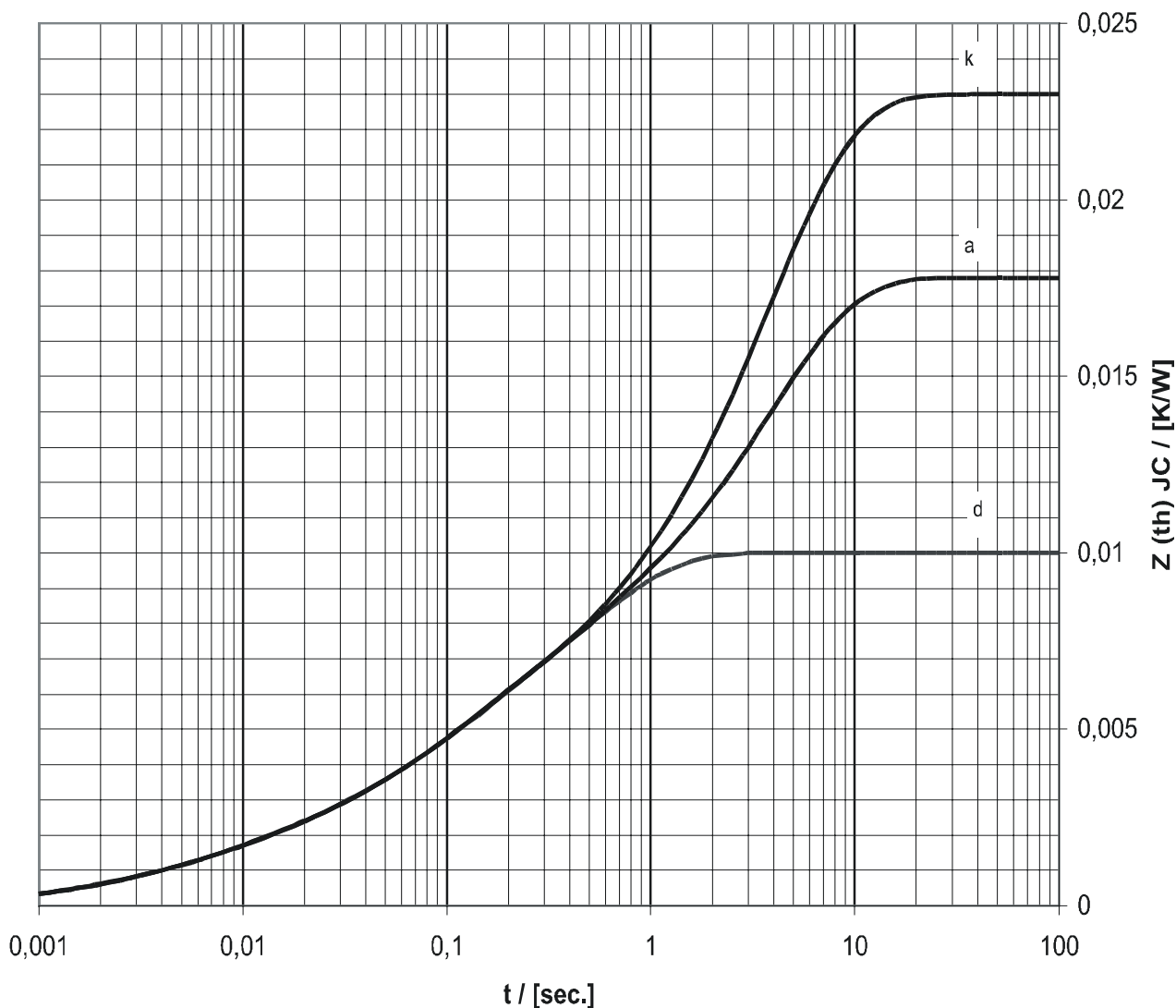

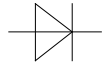

Stoßstrom / Grenzlastintegral Charakteristik
Surge current / I²t value characteristics

$$I_{FSM} = f(t_p) / \int i^2 dt = f(t_p)$$

Sine half-wave, T_{vj} = 140 °C, v_R = 0

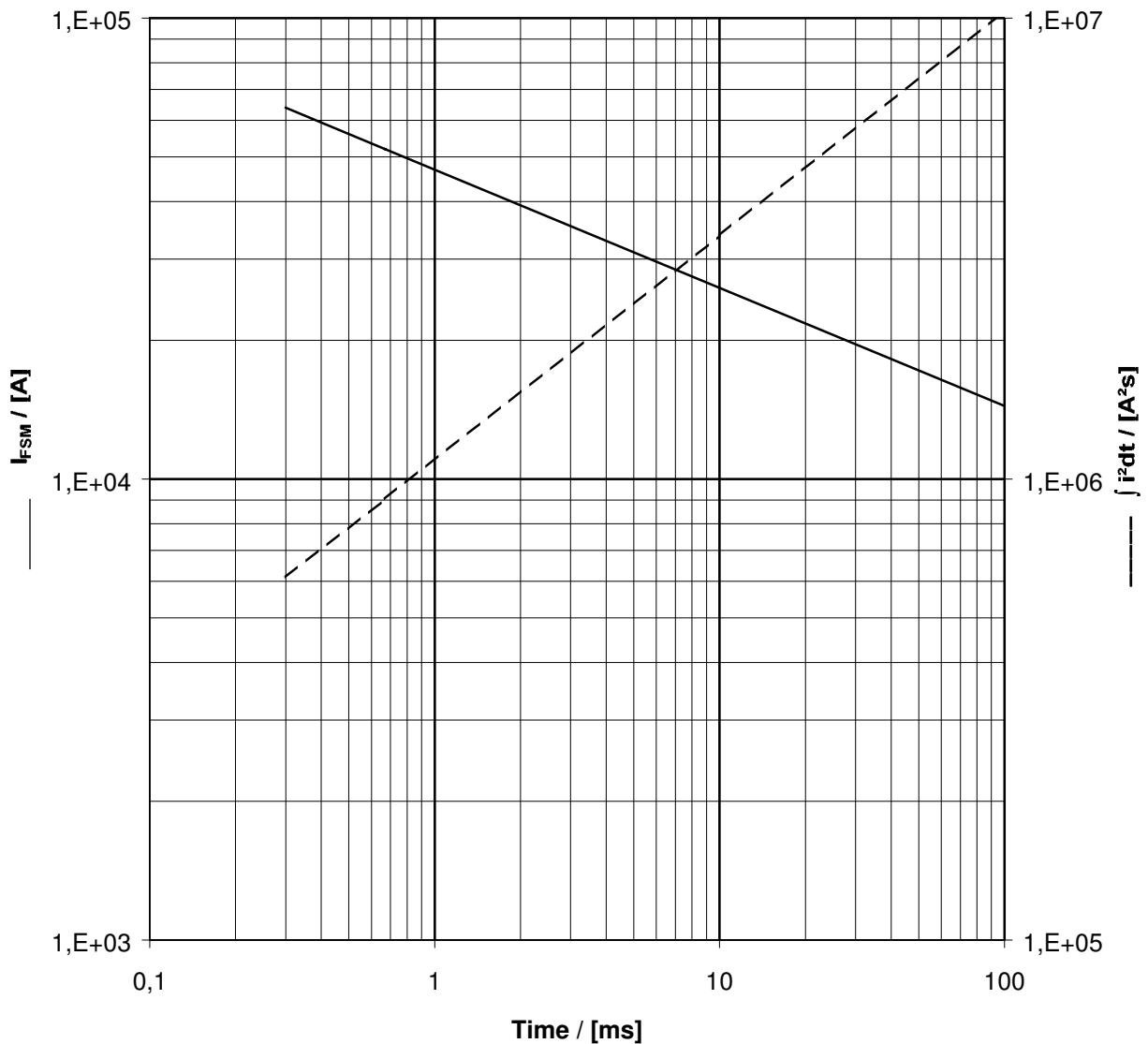

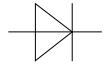

Sperrverzögerungsladung / recovered charge $Q_r = f(-di/dt)$

Upper limit of scatter range for $V_F = 3,8V @ 2500A, 140^\circ C$

Conditions:

$T_{vj} = 140^\circ C$

Parameter: I_{FM}

clamping circuit

$C_{CL} = 3 \mu F$

$R_{CL} = 68 \Omega$

34DSH65

$V_{CL} = 2800 V$

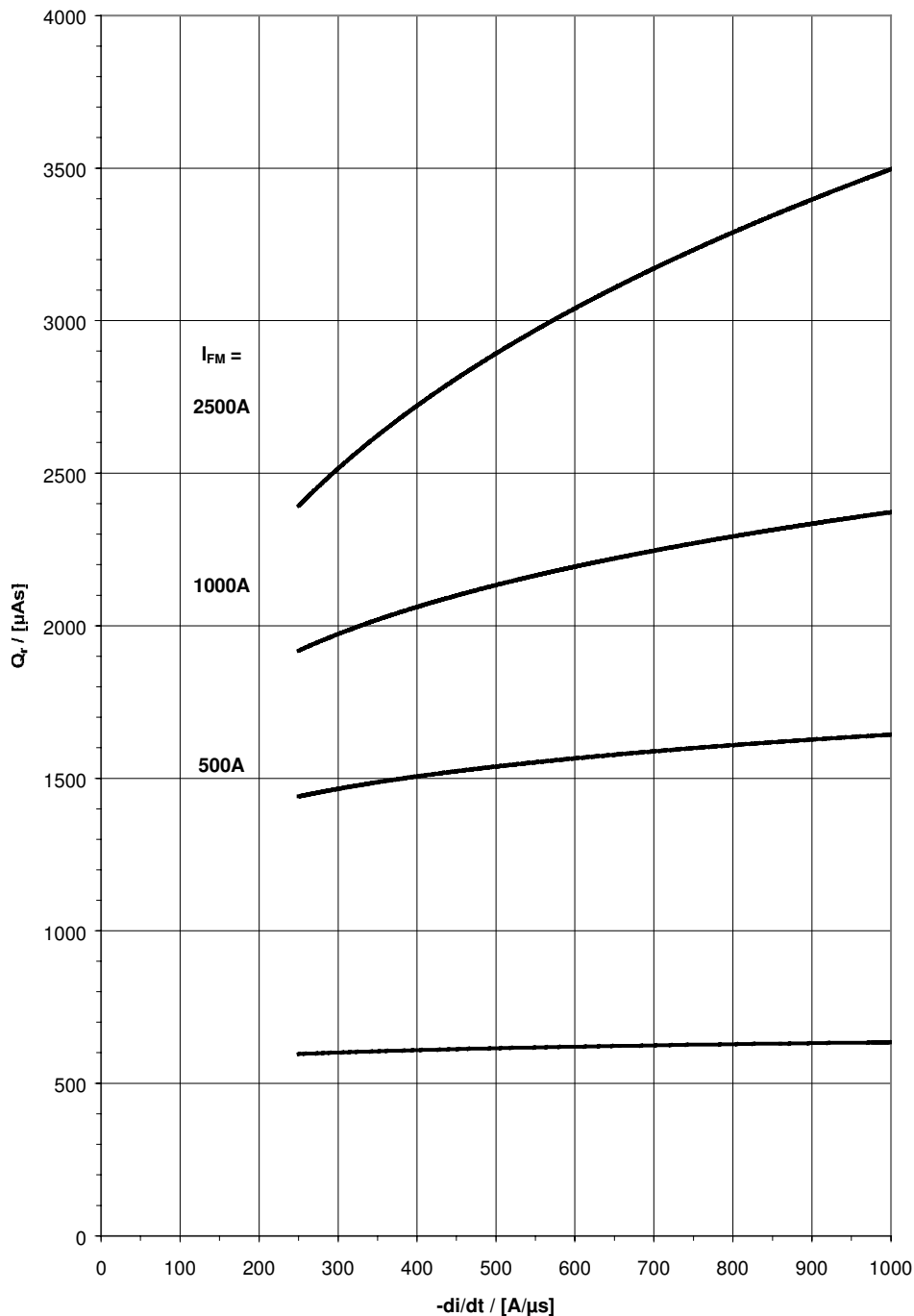



Rückstromspitze / peak reverse recovery current $I_{RM} = f (- di/dt)$

Upper limit of scatter range for $V_F = 3,8V @2500A, 140^\circ C$

Conditions:

$T_{vj} = 140^\circ C$

Parameter: I_{FM}

clamping circuit

$C_{CL} = 3 \mu F$

$R_{CL} = 68 \Omega$

34DSH65

$V_{CL} = 2800 V$

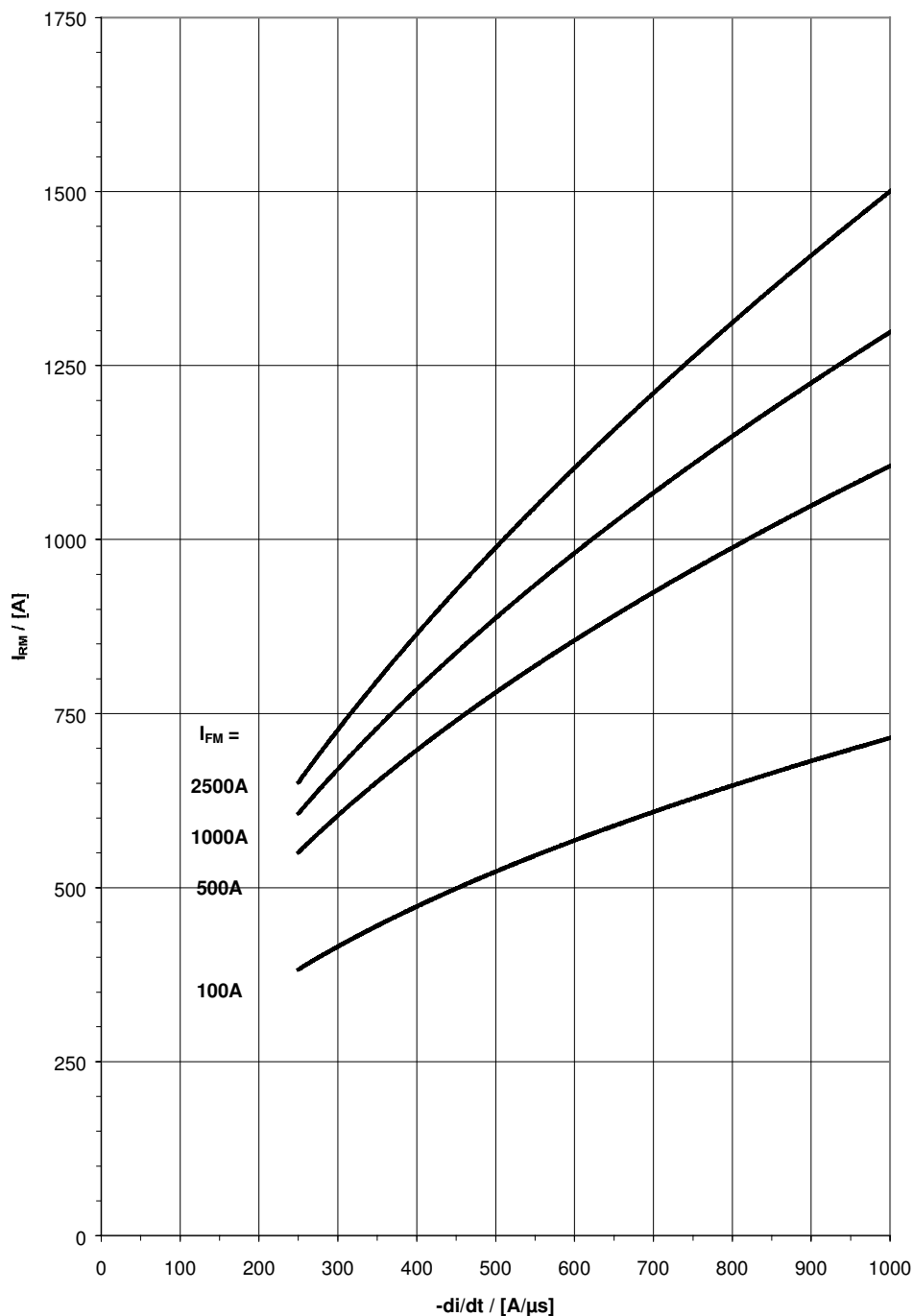

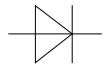

Ausschaltverlust Energie / turn-off energy $E_{off} = f(-di/dt)$

Upper limit of scatter range for $V_F = 3,8V @2500A, 140^\circ C$

Conditions:

$T_{vj} = 140^\circ C$

Parameter: I_{FM}

clamping circuit

$C_{CL} = 3 \mu F$

$R_{CL} = 68 \Omega$

34DSH65

$V_{CL} = 2800 V$

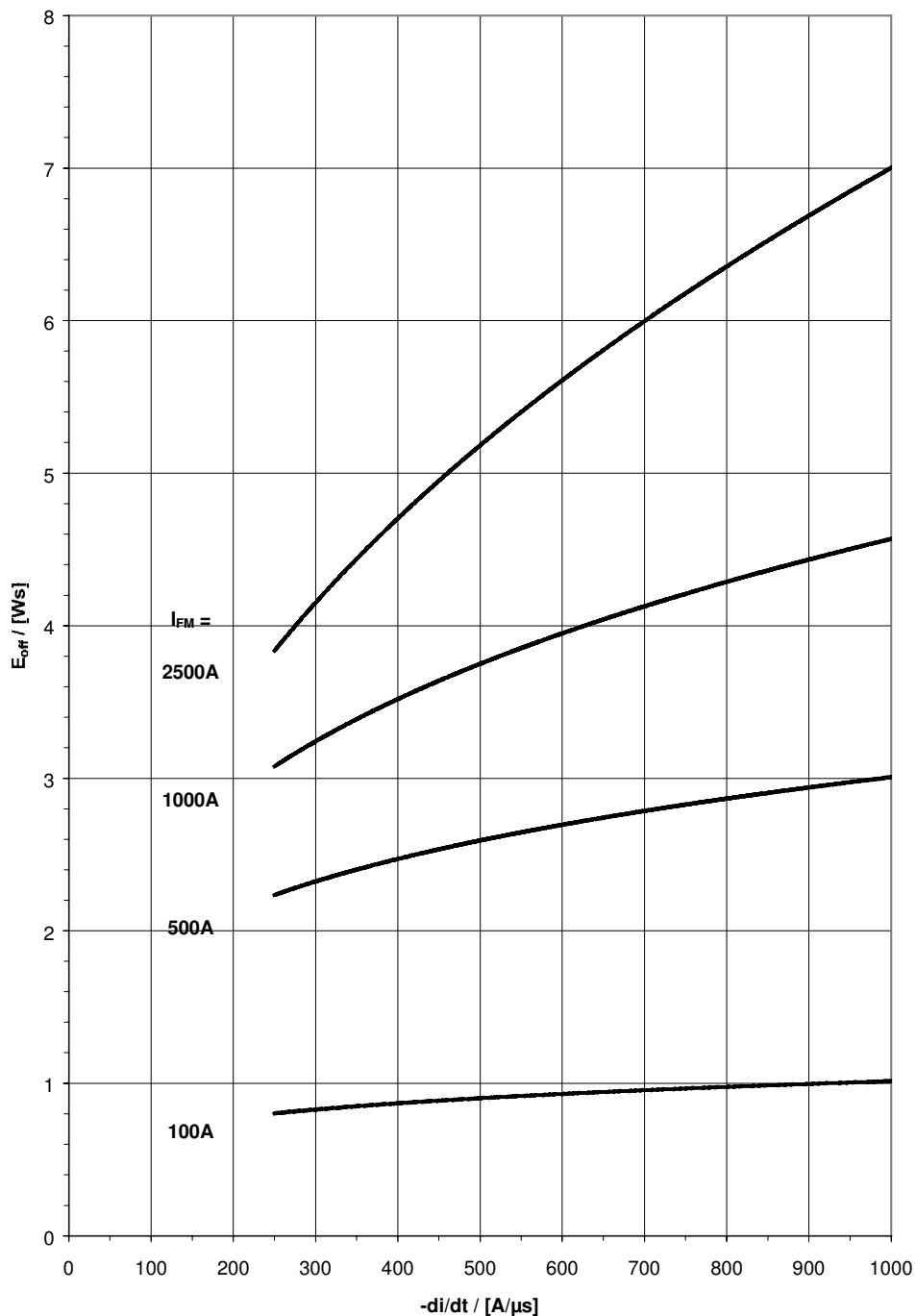

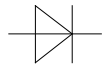

Spitzen-Durchlassverzögerungsspannung
peak forward recovery voltage $V_{FRM} = f (di_F/dt)$
typische Abhängigkeit / typical dependence

$T_{vj} = 140\text{ }^\circ\text{C}$, $I_{FM} = 4000\text{A}$

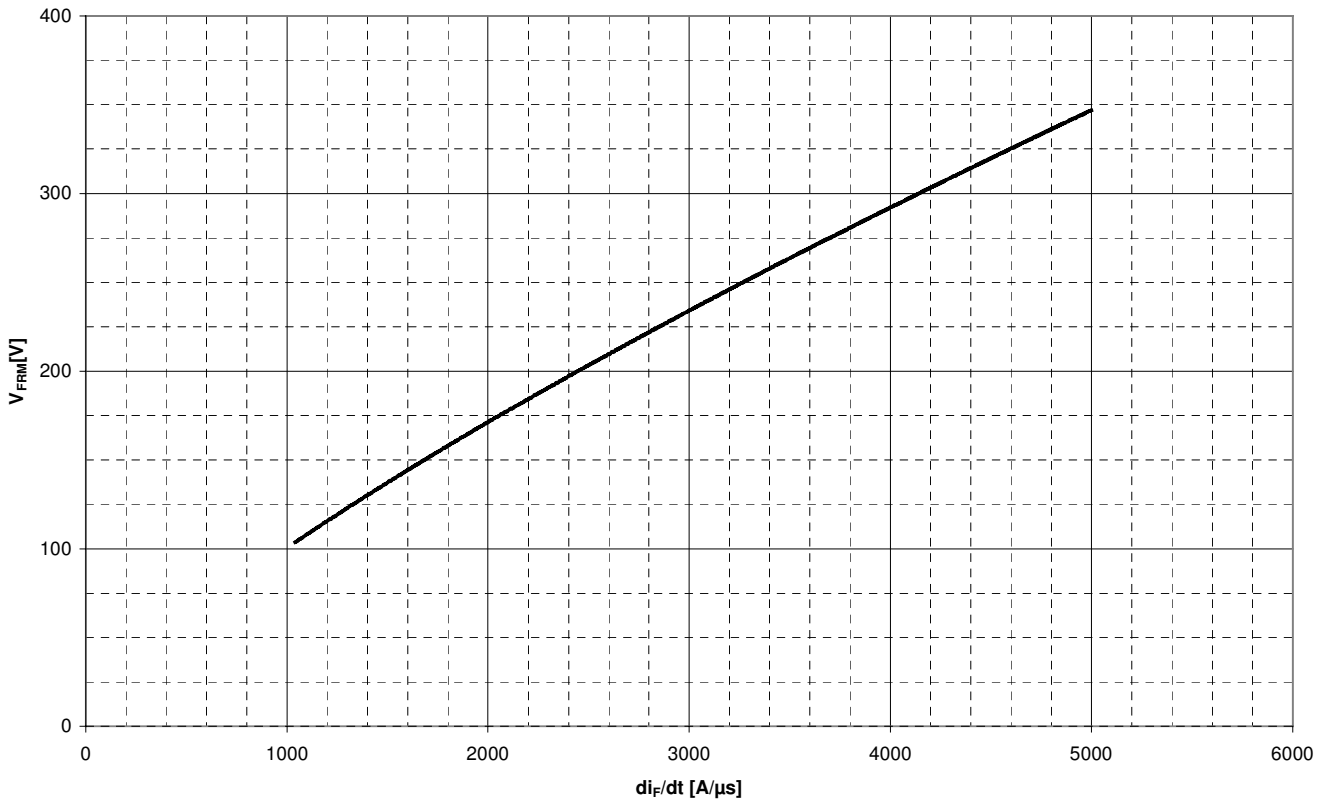

Terms & Conditions of Usage

Attention

The present product data is exclusively subscribed to technically experienced staff. This Data Sheet is describing the specification of the products for which a warranty is granted exclusively pursuant the terms and conditions of the supply agreement. There will be no guarantee of any kind for the product and its specifications. Changes to the Data Sheet are reserved.

You and your technical departments will have to evaluate the suitability of the product for the intended application and the completeness of the product data with respect to such application. Should you require product information in excess of the data given in the Data Sheet, please contact your local Sales Office via "www.eupec.com / sales & contact".

Warning

Due to technical requirements the products may contain dangerous substances. For information on the types in question please contact your local Sales Office via "www.eupec.com / sales & contact".